



***ATS-125***

# ***AIR NEEDLE SCALER***

**INSTRUCTION MANUAL**

Order Code: A036

## **Safety Air Tool Warnings**

1. Read and understand this entire manual before attempting assembly or operation.
2. Read and understand all warnings posted on the tool and in this manual. Failure to comply with all of these warnings may cause serious injury.
3. Replace warning labels if they become obscured or removed.
4. Do not use this tool for other than its intended use. If used for other purposes, Toolmaster disclaims any real or implied warranty and holds itself harmless from any injury that may result from that use.
5. Always wear approved safety glasses or face shield while using this tool. (Everyday eye glasses only have impact resistant lenses; they are not safety glasses.)
6. Wear ear protectors (plugs or muffs) if the noise exceeds safe levels.
7. Wear gloves and protective clothing if operation produces sparks or flying particles. Gloves should be tight-fitting, without frayed fingers or hanging threads. Keep hands and body away from the working area of tool.
8. Do not operate an air tool continually at full throttle without a work load on the tool.
9. The air tool must be properly lubricated before operating.
10. Never start a percussion type air tool (chipper, breaker, buster, etc.) without securing the tooling in the retainer and placing the tip against the work surface.
11. Do not operate air tool without its guards in place. Do not modify the tool.
12. Do not operate this tool while tired or under the influence of drugs, alcohol, or any medication.
13. Adopt a comfortable posture with proper balance, and maintain secure footing at all times. Non-slip footwear or anti-skid floor strips are recommended.
14. Do not wear loose clothing or jewellery. Confine long hair.
15. Excessive air pressure and too much free rotation may decrease life of the tool and may cause a hazardous situation.
16. Check air hoses for wear, and keep them away from heat and sharp edges. Repair or replace damaged air hose immediately. Do not carry tool by the air hose.
17. Air hose may cause tripping hazards; keep hose away from traffic areas.
18. Do not use this tool near flammable objects, or in potentially explosive environments. Do not use near live electrical wires.
19. Do not use power tools in damp or wet location, or expose them to rain. Keep work area well lighted.
20. Do not leave a connected tool unattended. When not in use, disconnect tool from air source.
21. Shut off air supply and discharge any residual pressure from tool before removing hose, making adjustments, changing accessories, or storing tool.
22. Make sure tool is switched off, and your finger off the trigger, before connecting to air supply. Remove adjusting keys before operating
23. Keep visitors a safe distance from the work area. Keep children away.



### Safety Specific For Air Scalers

1. When not using an Air Needle Scaler, always disconnect the tool from the air supply, in order to prevent unintended start.
2. Appropriate footwear must be worn. Shoes must be fully enclosed. No open-toed shoes.
3. Put the required personal protective equipment and proper eye protection must be worn at all times by tool user and bystanders
4. Repetitive motions or exposure to vibration may be harmful to your hands and arms.
5. Before using the Air Needle Scaler, know what is directly underneath the work area or work piece
6. Always remove the tool from air supply and activate trigger to bleed air-line before making any adjustments, changing accessories, or doing any maintenance or service on the tool.

**Warning:** Some dust, fumes and gases created by power sanding, sawing, grinding, drilling, welding and other construction activities contain chemicals that may cause cancer and birth defects or other reproductive harm. Some examples of these chemicals are:

- lead from lead based paint
- crystalline silica from bricks, cement and other masonry products
- arsenic and chromium from chemically treated timber

Your risk of exposure varies, depending on how often you do this type of work. To reduce your exposure to these chemicals, work in a well-ventilated area and work with approved safety equipment, such as dust masks that are specifically designed to filter out microscopic particles

### Technical Specifications

Number of Needles (No.)	12
Stroke Length (mm)	28mm
Strokes per min (BPM)	5000
Air Requirements	3CFM (85 l/min)
Maximum Air Pressure	90 PSI
Recommended Air Hose	10mm
Inlet	1/4" BSPT
Sound Pressure	86 dBA
Length	291mm
Weight	1.3kg



### WARNING!

Misuse of compressed air is **HIGHLY DANGEROUS** and may cause permanent **INJURY** or **DEATH** from flying debris.

## Setup

Any missing parts or damage should be reported immediately to your Toolmaster distributor. Do not use a damaged tool. Read this instruction manual thoroughly for operation, maintenance and safety instructions. The diagram below is the ideal setup position. The lubricator is optional and if not used, then a few drops of Pneumatic Tool Oil need to be added to the airline connection before operation. Add a few more drops after each hour of continual use.

## Air Supply

The recommended air system is shown in Fig.1.

1. Use proper air hose size (refer to tool specifications). The hose should be just long enough to serve the working area. Excessive hose length will cause pressure drop.



**WARNING!** Ensure that the air supply is clean and does not exceed 90psi. Too high an air pressure and/or unclean air will shorten the life of the air tool due to accelerated wear, and may cause damage and/or personal injury.

2. Drain the compressor air tank daily. Water in the air line will damage the air tool.
3. Clean the compressor air inlet filter screen weekly.
4. Line pressure should be increased to compensate for unusually long air hoses (over 8 meters).  
The minimum hose bore should be 10mm and fittings must have the same inside dimensions.
5. Keep hoses away from heat, oil and sharp edges. Check hoses for wear, and make certain that all connections are secure.

**IMPORTANT:** The leader hose is optional, but connecting a quick-change coupling directly to the tool is not recommended, as vibration may cause the connection to fail. For the best result, add a leader hose and install any quick-change couplings farther down the line.

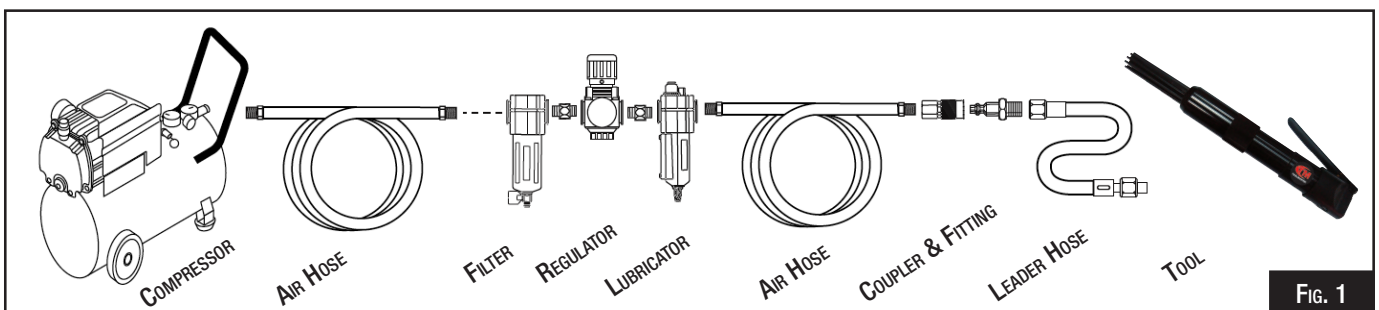

**WARNING:** Operating the tool at pressures over the rated capacity may cause severe damage and/or personal injury. Do not exceed 90 PSI while operating the tool. Do not use an accessory rated at a lower maximum pressure than the tool.

## Operating Instructions

1. Disconnect the air tool from the air line.
2. Insert the 12 needles into the Air Needle Scaler tube and secure.
3. If an automatic oiler is not used, add a few drops of Pneumatic Tool Oil to the airline c o n n e c t i o n before use. Add a few drops more after each hour of continual use.
4. Set the air pressure on your compressor to 90 PSI. Do not exceed the recommended air pressure of 90 PSI
5. Check the air connections for leaks.
6. Connect the air line to the Air Needle Scaler.
7. Grip the Air Needle Scaler firmly, and depress the operating lever to begin operation.(See Fig. 2)
8. With safety glasses on, gently squeeze the trigger and move slowly along the workpiece. Do not push down on the scaler; let it do the work. If it does not do the intended job to satisfaction, examine your scaler to see if it is worn or dull.
9. If the tool requires more force to accomplish the task, verify that the tool receives sufficient unobstructed airflow (CFM) and increase the pressure (PSI) output of the regulator up to the maximum air pressure rating of this tool.



**CAUTION! TO PREVENT INJURY FROM TOOL OR ACCESSORY FAILURE:**

*Do not exceed the tool's maximum air pressure rating. If the tool still does not have sufficient force at maximum pressure and sufficient airflow, then a larger tool may be required.*

10. To prevent accidents, turn off the tool, detach the air supply, safely discharge any residual air pressure in the tool, and release the throttle and/or turn the switch to its OFF position after use. Clean external surfaces of the tool with clean, dry cloth, and apply a thin coat of tool oil, then store the tool indoors out of children's reach

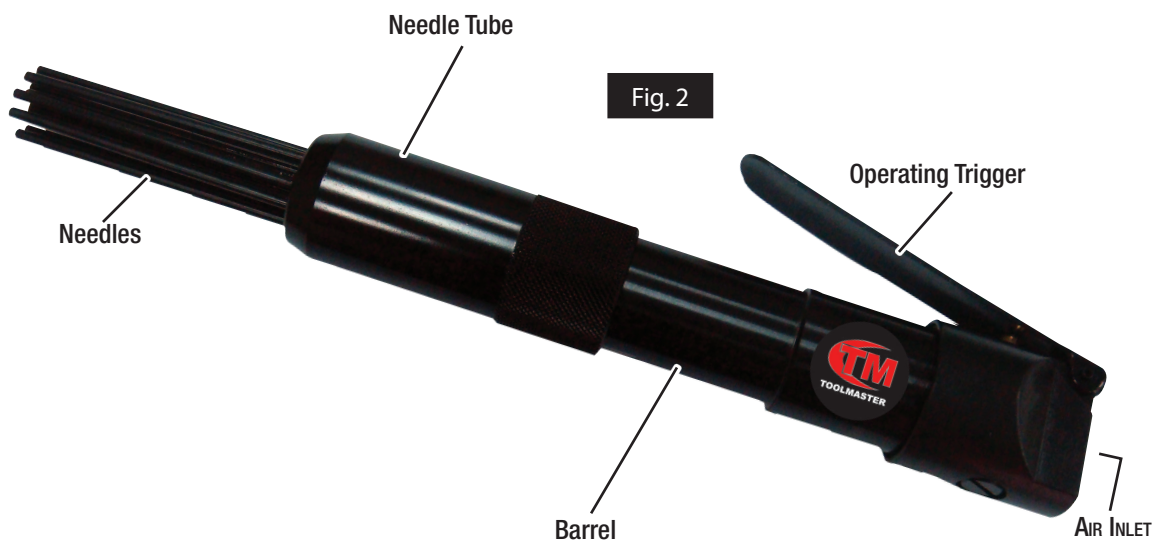

### Spare Parts

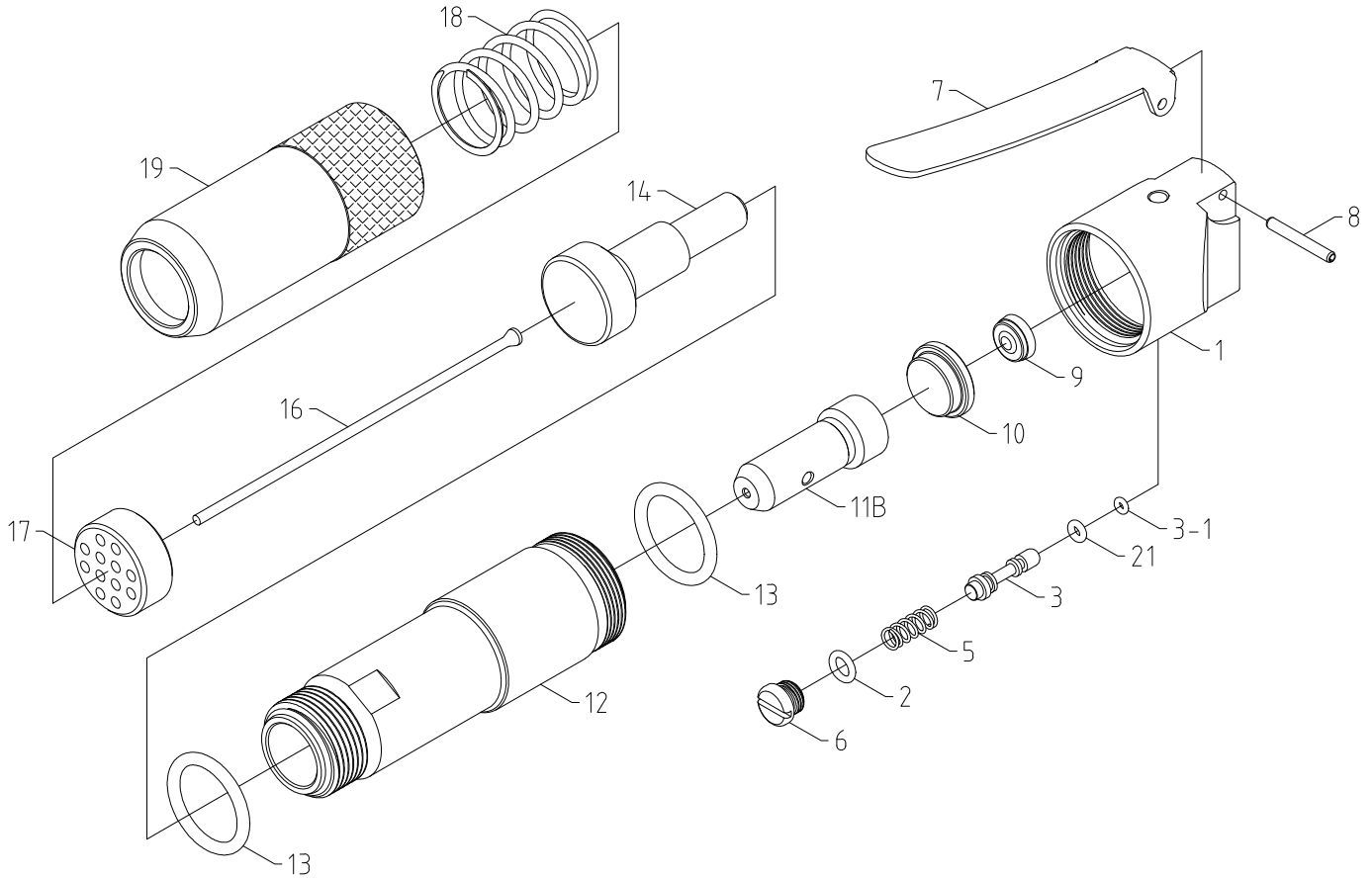

Item	Fig. No.	Description	Qty	Item	Fig. No.	Description	Qty.
1	P124-28801	BACKHEAD	1	12	P121-28812	CYLINDER	1
2	P110-28802	O-RING P6(D5.8*W1.9)	1	13	P110-28813	O-RING P24(D23.7*W3.5)	2
3	P127-28803	VALVE STEM	1	14	P112-28814	DRIVER	1
3-1	P110-100051	O-RING(D2*W1 .5)	1	16	P103-3125	NEEDLE(03*125L)	12
5	P108-28805	VALVE SPRING	1	17	P104-28817	NEEDLE HOLDER(03*12HOLES)	1
6	P113-28806	VALVE CAP	1	18	P108-28818	COMPRESSION SPRING	1
7	P111-28807	LEVER	1	19	P109-28819	FRONT TUBE	1
7-1	P111-28807A	LOCKING LEVER	1	21	P110-28821	O-RING P3(D2.8*W1.9)	1
8	P129-11008	SPRING PIN(03*24L)	1				
9	P132-28809	BUMPER	1				
10	P122-28810	CYLINDER CAP	1				
11	P120-28811B	PISTON	1				



### WARNING!

**Safety goggles are required for workers and visitors to wear in hazardous areas to prevent injury and maintain safe eye protection**

## Troubleshooting

Review the troubleshooting and procedures in this section if a problem develops with your Air Tool. If you are still unable to resolve the problem, then contact your local Toolmaster service centre. If additional help with a procedure is required, then contact your distributor.

**Note:** Make sure you have the model of the machine, serial number, and manufacture date before calling.

<i>Symptoms</i>	<i>Possible Cause</i>	<i>Possible Solution</i>
Decreased output.	<ol style="list-style-type: none"> <li>1. Not enough air pressure and/or air flow.</li> <li>2. Obstructed throttle.</li> <li>3. Incorrect lubrication or not enough lubrication.</li> <li>4. Blocked air inlet screen (if equipped).</li> <li>5. Air leaking from loose body housing.</li> <li>6. Mechanism contaminated.</li> <li>7. Vane wear or damage.</li> </ol>	<ol style="list-style-type: none"> <li>1. Check for loose connections and make sure that air supply is providing enough air flow (CFM) at required pressure (PSI) to the tool's air inlet. Do not exceed maximum air pressure.</li> <li>2. Clean around throttle to ensure free movement.</li> <li>3. Lubricate using air tool oil and grease according to directions.</li> <li>4. Clean air inlet screen of buildup.</li> <li>5. Make sure body housing is properly assembled and tight.</li> <li>6. Have qualified technician clean and lubricate mechanism. Install in-line filter in air supply as stated in Setup: Air Supply.</li> <li>7. Replace all vanes.</li> </ol>
Housing heats during use	<ol style="list-style-type: none"> <li>1. Incorrect lubrication or not enough lubrication.</li> <li>2. Worn parts.</li> </ol>	<ol style="list-style-type: none"> <li>1. Lubricate using air tool oil and grease according to directions.</li> <li>2. Have qualified technician inspect internal mechanism and replace parts as needed.</li> </ol>
Severe air leakage (Slight air leakage is normal, especially on older tools.	<ol style="list-style-type: none"> <li>1. Cross-threaded housing components.</li> <li>2. Loose body housing.</li> <li>3. Damaged valve or housing.</li> <li>4. Dirty, worn or damaged valve.</li> </ol>	<ol style="list-style-type: none"> <li>1. Check for incorrect alignment and uneven gaps. If cross-threaded, disassemble and replace damaged parts before use</li> <li>2. Tighten housing assembly. If housing cannot tighten properly, internal parts may be misaligned</li> <li>3. Replace damaged components.</li> <li>4. Clean or replace valve assembly.</li> </ol>

## Maintenance

### 1. Daily - Air Supply Maintenance:

Every day, maintain the air supply according to the component manufacturers' instructions.

Maintain the lubricator's oil level. Use Pneumatic Tool Oil (Order Code A037)

Drain the moisture filter regularly.

Performing routine air supply maintenance will allow the tool to operate more safely and will also reduce wear on the tool.

### 2. Quarterly (every 3 months) – Tool Disassembly, Cleaning, and Inspection:

Have the internal mechanism cleaned, inspected, and lubricated by a qualified technician.

### 3. For a full service contact your local Toolmaster service agent.

### 4. When not in use, disconnect from air supply, clean nibbler and store in a safe and dry place.



***INDUSTRIAL AIR TOOLS***